

Ordering Information

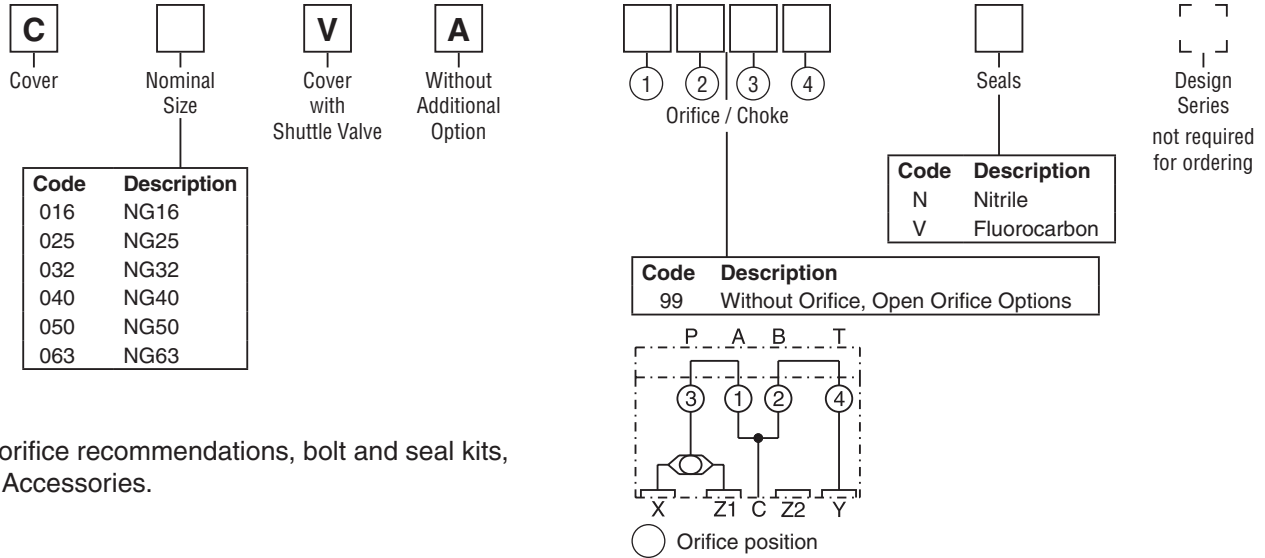

For orifice recommendations, bolt and seal kits, see Accessories.

Dimensions

Inch equivalents for millimeter dimensions are shown in (**)

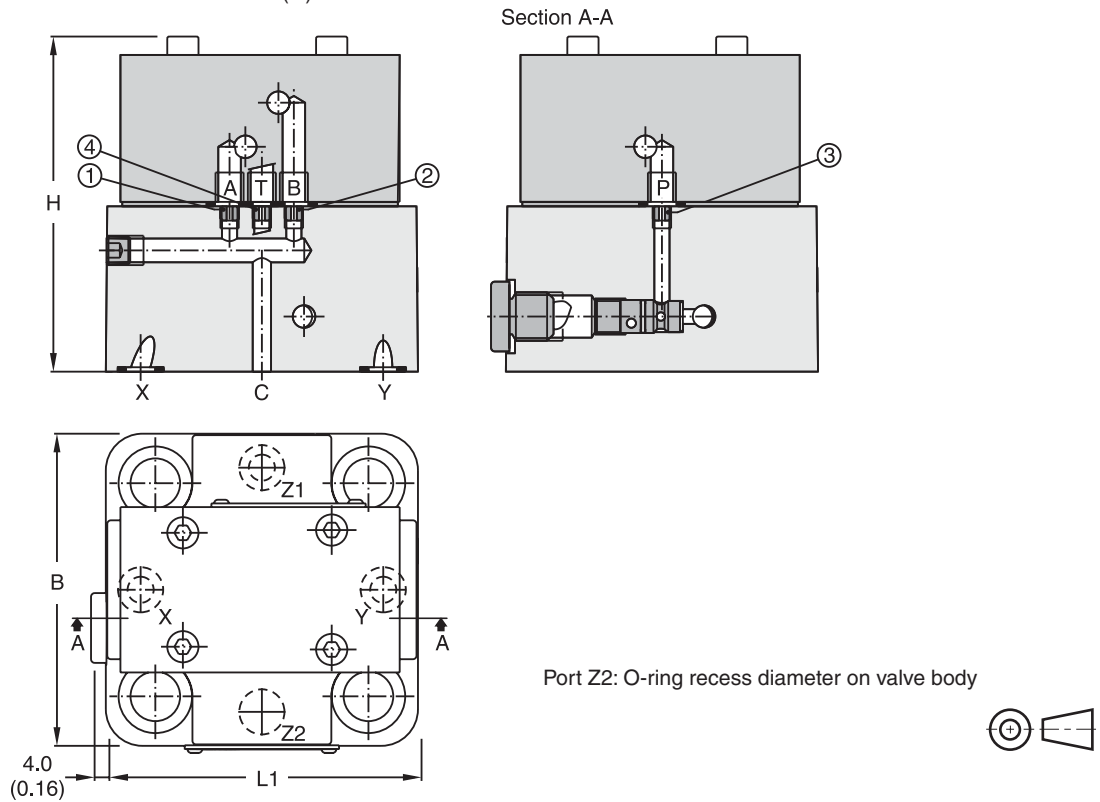

Size	B	H	L1	Orifice Thread			
				①	②	③	④
NG16	65.0 (2.56)	86.5 (3.41)	85.0 (3.35)	M5	M5	M5	M5
NG25	85.0 (3.35)	91.5 (3.60)	85.0 (3.35)	M5	M5	M5	M5
NG32	102.0 (4.02)	96.5 (3.80)	102.0 (4.02)	M5	M5	M5	M5
NG40	125.0 (4.92)	106.5 (4.19)	125.0 (4.92)	M6	M6	M6	M6
NG50	140.0 (5.51)	126.5 (4.98)	140.0 (5.51)	M8	M8	M8	M8
NG63	180.0 (7.09)	141.0 (5.55)	180.0 (7.09)	M8	M8	M8	M8